

E10 Plastic Specifications

Materials of Construction (Wetted Parts)

Part	Materials
Pump Housing	Thermoplastic
"O" Ring	EPDM or Viton
Impeller	Fiber Reinforced Thermoplastic
Bearing	Carbon/Aluminum Ceramic
All Other Wetted Parts	316 Stainless Steel or Plastic

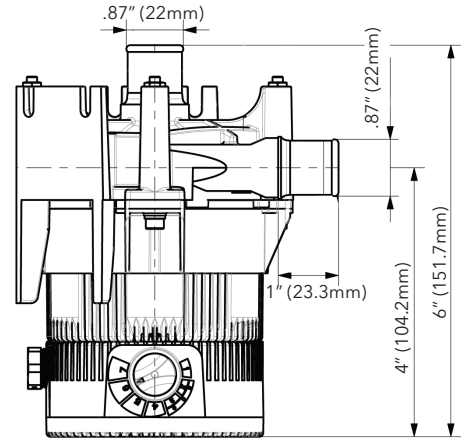

E10 Plastic 3/4" NPT

